

Series Protection for Power-Line Transients

This application note describes a circuit that protects an n-channel power MOSFET against low and high voltages. It includes a high-side switch-driver IC and fast-response, 3-transistor, overvoltage detector.

Voltage transients found on low-voltage power lines can sometimes attain amplitudes many times the nominal voltage level. Those occurrences create the need for protection against the application of improper power levels.

The usual way to protect sensitive circuitry against overvoltage is to add parallel clamps whose high energy-absorption capability is preceded by fuses or other current-limiting devices. Other cases require the use of high-voltage series protection (instead of parallel clamps) due to the difficulty in resetting or replacing fuses, an inaccessible operating environment, or the need for uninterrupted operation.

The series-protection circuit of **Figure 1** turns the power switch off using a series-connected, high-voltage, n-channel MOSFET power switch (Q1) and a fast overvoltage detector. The power switch and series-connected power rectifier (D1) protect the load against high-voltage transients and continuous overvoltage (up to 500V, of either polarity).

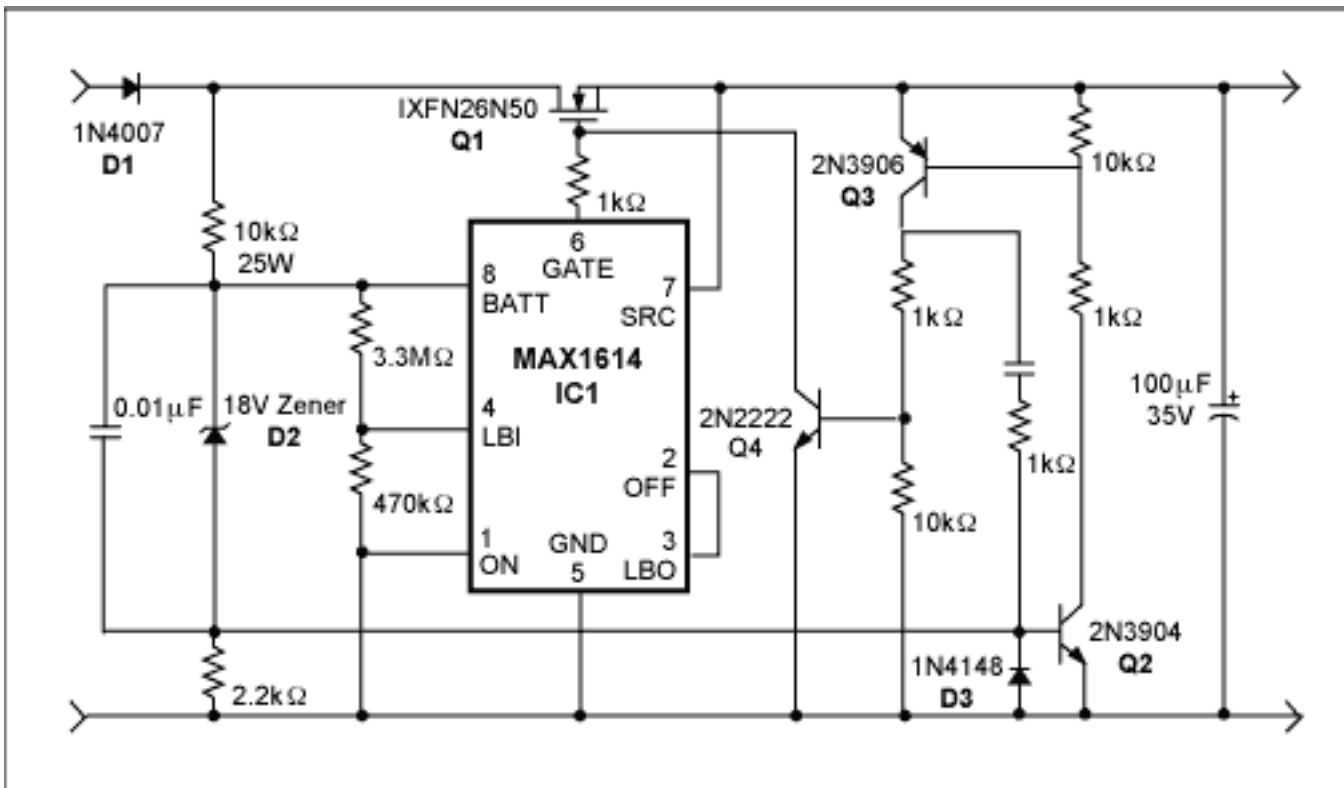

Figure 1. This circuit protects a load (connected to the right pair of terminals) against undervoltage and high-voltage transients in the supply voltage (connected to the left pair of terminals).

In the circuit, which powers loads up to 1A from a nominal 12V power line, a high-side switch driver (IC1) biases the power switch fully on. You can increase the maximum load current by changing D1 and Q1. To guard against low supply voltage, IC1 includes an undervoltage-lockout feature that allows operation only when the line voltage is above 10V. To protect against overvoltage, the circuit includes a 3-transistor, no-bias-current, fast (50ns operation) overvoltage detector that triggers when the input voltage reaches about 20V. At that time Q4 "crowbars" the gate of the power switch to ground, turning it off hard.

Rising overvoltage first turns on zener diode D2, which protects the IC by clamping the voltage across it to about 18V. Zener current flows through the 2.2kΩ resistor, producing a base voltage that turns on Q2. That action initiates a rapid sequence: Q3 turns on, which turns on Q4, which turns off Q1 by quickly discharging its gate capacitance.

Circuit performance is illustrated by applying a 150V transient to the supply voltage while the circuit output is delivering 1A at 12 Volts (**Figure 2**). The internal impedance of the transient source is 1Ω, and the risetime of the applied voltage is 1μs. The circuit draws 20μA during normal operation, including 3μA by the undervoltage-lockout voltage-sensing divider and 17μA by IC1.

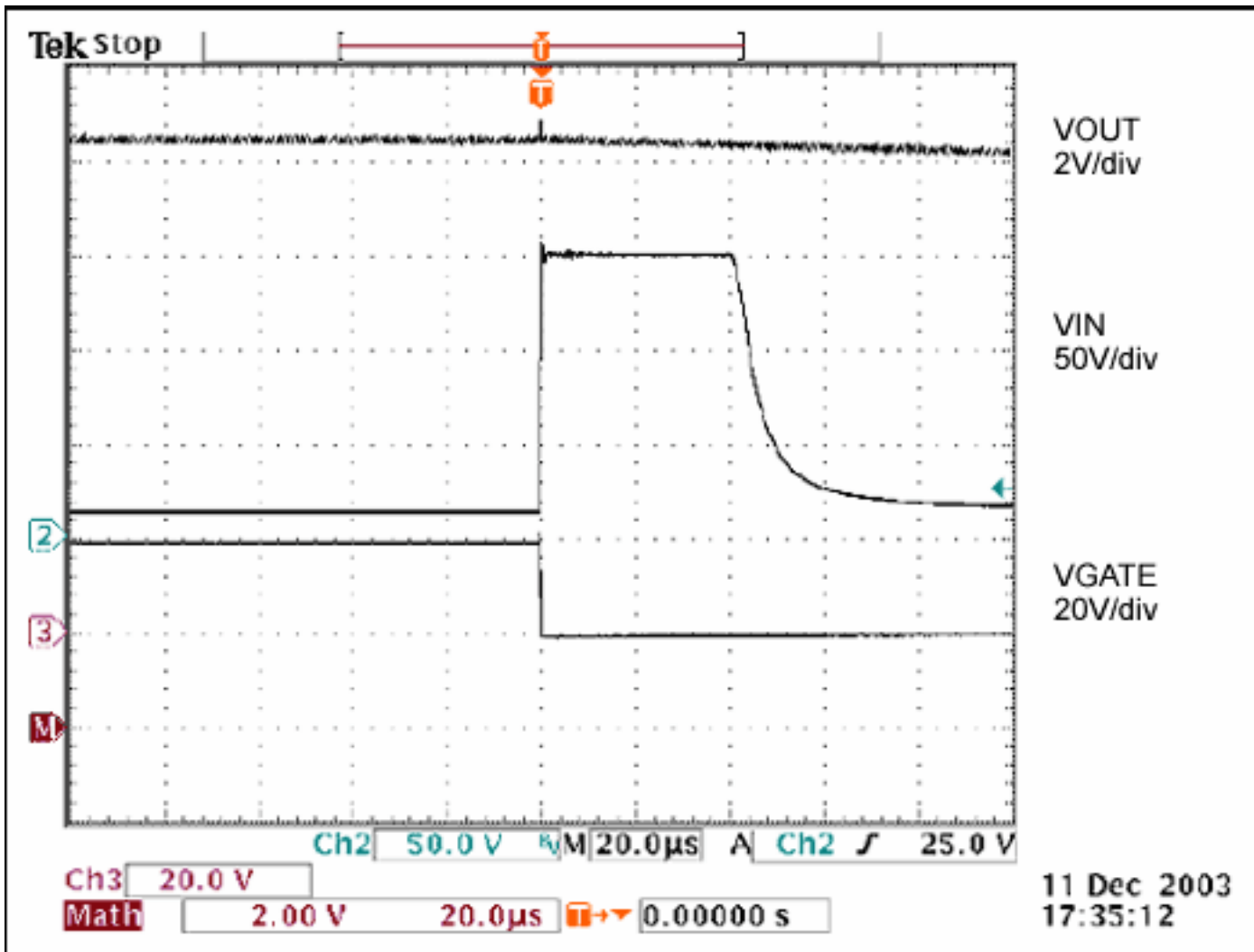

Figure 2. A 150V transient applied to VIN of the Figure 1 circuit has little effect on VOUT.

If you need high-temperature operation, note that the gate-current output of IC1 is relatively limited. Your design calculations for high temperature should also pay close attention to leakage currents contributed by the other circuit components.

A similar version of this article appeared in the October 14, 2004 issue of *EDN* magazine.

More Information

MAX1614: [QuickView](#) -- [Full \(PDF\) Data Sheet](#) -- [Free Samples](#)